



OFFROAD 770

Glazing Robot

Max Load
770 lbs



Vertical
Working Height

8' 1"

Max
Overhead Height

9' 0"



MAVLift.com



The MAVLift 770 Offroad might be the smallest of the off-road series, but it comes standard with some of the series most attractive options.

Offering a lifting capacity of up to 770 lbs and the Advanced Articulating Joint as a standard feature, the MAVLift 770 can pick up glass or materials from the floor or counter height and tilt them into an overhead position seamlessly.

Dimensions

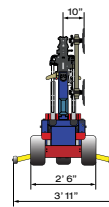
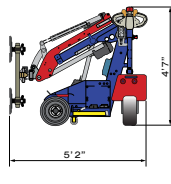
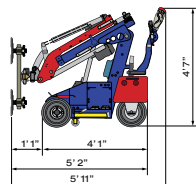
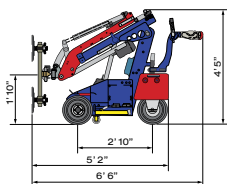
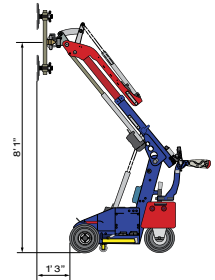
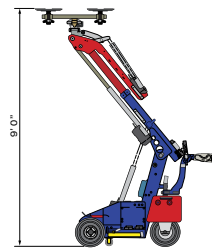
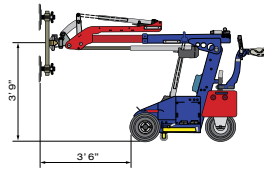
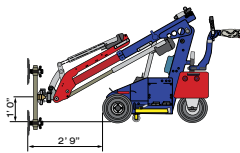
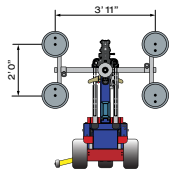
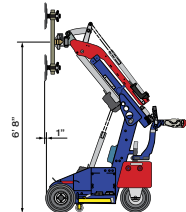
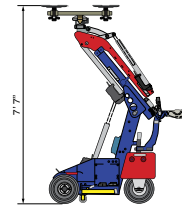
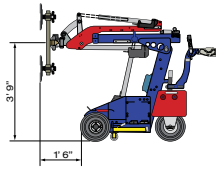
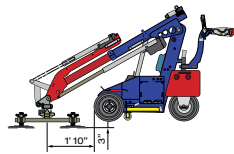
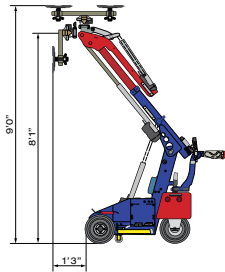

MAV OFFROAD
LIFT 770
Dimensions

Couple the range of the Advanced Articulating Joint and the MAVLift's signature Synchronous Controls, (which ensure a constant inclination angle of the vacuum unit) and you have a high performance and versatile lifting robot.

Built for unfinished or unrefined jobsites, the MAVLift 770 has rugged tires and high performance front wheel drive. Built to be compact enough to fit through standard doors or in an elevator, this off-road glass lifting robot makes moving and installing glass safer and faster.



Rated Load Chart

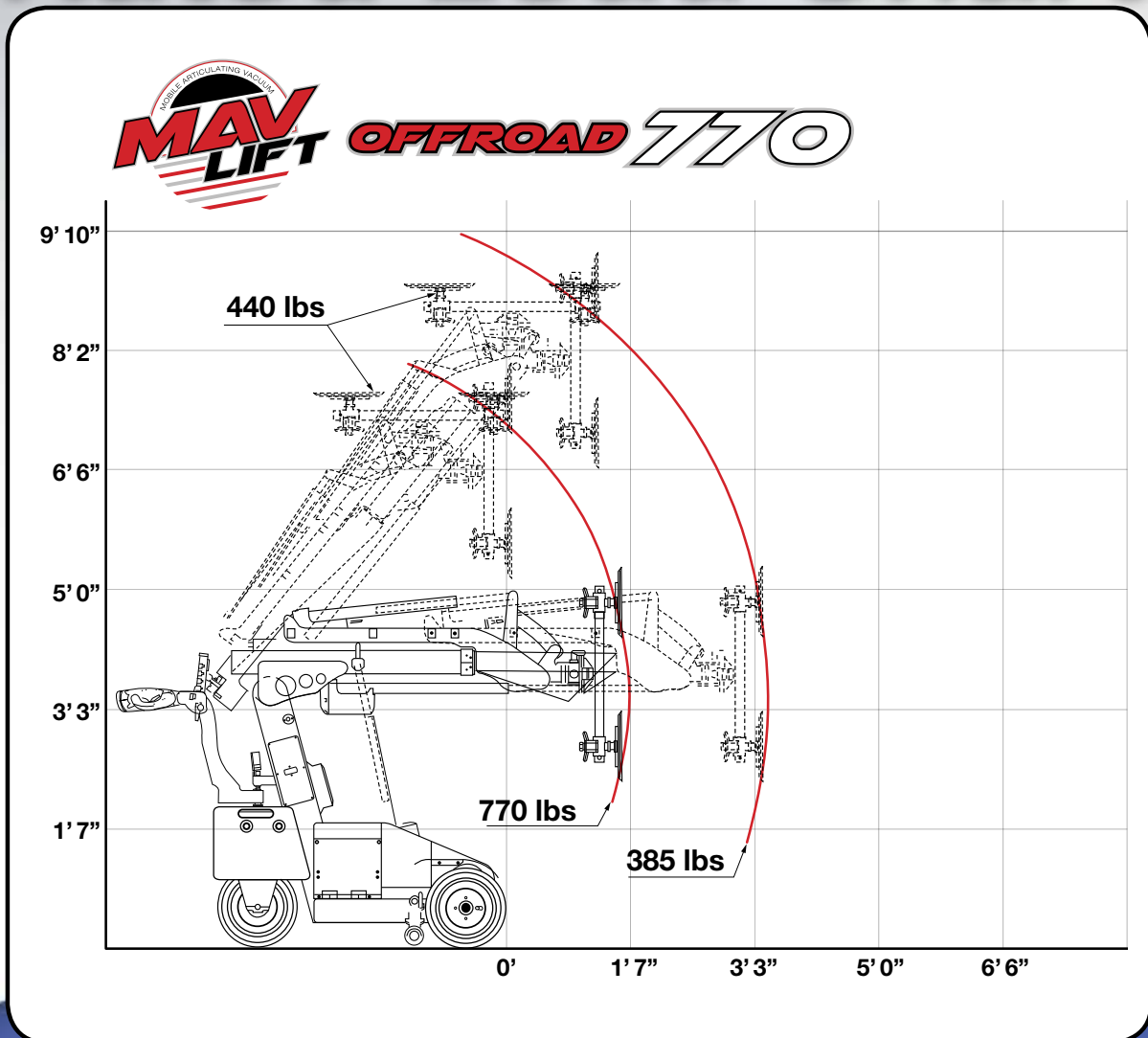



OFFROAD 770

Specifications

Technical Data

Max Load Capacity	770 lbs
Machine Weight (Without Counterweights)	723 lbs
Machine Weight (With removable Counterweights installed)	1173 lbs
Jib Angle	125°
Maximum Permitted Slope	16°
Powered Lateral Sideshift	4"
Power Requirements	Battery: 110v/240v Charger Pump: 12v DC
Vacuum System	2 Vacuum Pumps 4 Cups

Accessories

- Load Forks - Utilize your MAVLift for material handling
- Hook Adapter - Remove the cup system and add a lifting hook to your MAVLift
- Forklift Platform - Utilize your MAVLift as an extension of your forklift
- LED Light - LED with magnetic socket powered by the MAVLift's battery pack
- Loading Ramps - Two 8' x 3' load ramps for easy loading into a transport vehicle or trailer (2200 lbs max capacity)
- Weather Cover for MAVLift Offroad 770

Standard Features

- Lifting Unit Electrically Turns in All Directions and Telescopes to the Front
- Synchronous Controls- automatically keeps a constant inclination angle of vacuum unit
- Advanced Articulated Joint- Allows for additional electric articulation of suction unit so it may swivel from the horizontal plane to overhead
- Adjustable Suction Frame
- Wired Remote Control
- Suitable for Overhead Lifting
- 4" Lateral Sideshift (left and right)
- 180° Suction Unit Rotation (manual left and right)
- 90° Slew of Vacuum Unit (left and right)
- Designed to fit in a standard elevator
- Two Independent Vacuum Circuits with Two Pumps and Two Vacuum Reserve Tanks
- Robotic Arm Powered by Electric Actuators for Precision Control
- Operates on Two 12v DC Rechargeable Batteries or While Plugged into Standard Outlet

Safety Features

- Overload Switch
- Stop Switch
- Vacuum Lost/Overloading Indicator

Product specifications are subject to change without notice. No specific training or license is required to operate the MAVLift in most areas, but operators are responsible for knowing and meeting all safety requirements and regulations. Not responsible for content errors.



MAVLift.com